

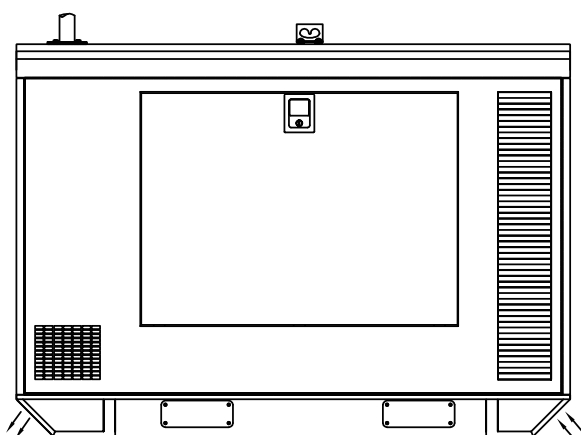

### Standard Features

- Kohler Co. provides one-source responsibility for the generating system and accessories.
- The generator set and its components are prototype-tested, factory-built, and production-tested.
- Two-year limited warranty covers all systems and components.
- Industrial diesel engine with 12-volt battery charging alternator.
- Single-bearing alternator with class H insulation.
- 50°C (122°F) ambient radiator.
- Subbase fuel tank.
- Vibration isolators.
- Dry type air filter
- Fuel Water separator.
- Main line breaker.
- Starting battery and cables with inbuilt battery charger.
- CPCB-certified sound enclosure.
- Conveniently located fuel level indication and fuel filling point.
- Single point lifting arrangements.
- Operation and installation literature.



### Generator Set Ratings

Genset	Engine	Alternator	Voltage	PH	Hz	Prime Rating	
						kW/kVA	Amps
KE15	G20	ECP3-3L/4	240/415	3	50	12/15	20
KES15	G20	ECP28-2LN/4	240	1	50	12/15	62.5

**PRIME POWER RATINGS:** Prime power ratings apply to installations where utility power is unavailable or unreliable. At varying load, the number of generator set operating hours is unlimited. A 10% overload capacity is available for one hour in twelve. Ratings are in accordance with ISO-8528/1, overload power in accordance with ISO-3046/1 and BS 5514. For limited running time and base load ratings, consult the factory. Obtain the technical information bulletin (TIB-101) on ratings guidelines for the complete ratings definitions. The generator set manufacturer reserves the right to change the design or specifications without notice and without any obligation or liability whatsoever.

# Alternator Specifications

- Alternator meets BS EN 60034 and the relevant section of other international standards such as BS5000, VDE 0530, NEMA MG1-32, IEC34, CSA C22.2-100, AS1359.
- Self-ventilated and dripproof of IP23 construction.
- Superior voltage waveform form a 2/3 pitch wound stator.
- Sustained short circuit current of upto 300% of the rated current for upto 20 seconds.

Specifications	Alternator
Type	4 Pole
Exciter type	Brushless
Leads, quantity type	12, Reconnectable
Voltage regulator	DSR
Insulation	
- Material	Class H
- Temperature rise, Prime	125°C
Bearing: quantity, type	1, Sealed
Coupling	Flexible Disc
Voltage regulation	<+/-1%
Prime at 125°C, kVA	15
Direct axis subtransient reactance (X"d)%	9.10

## Application Data

### Engine

#### Engine specifications

Engine model	G20
Engine type	Natural Aspiration
Cylinder arrangement	3, inline
Displacement, L (cu. in.)	2.15 (131.2)
Bore and stroke, mm (in.)	91 x 110 (3.58 x 4.33)
Compression ratio	17.5
Piston speed, m/min. (ft./min.)	330 (1082)
Rated rpm	1500
Max.power at rated rpm, kWm (BHP)	22 (29.6)
Governor: type	Mechanical
Frequency regulation, no-load to full load	ISO 5%
Frequency regulation, steady state	+/- 2.5%
Frequency, Fixed, Hz	50
Air cleaner type, all models	Dry

### Exhaust

#### Exhaust System

Exhaust Manifold type	Dry
ExhaustflowatratedkW,kg/hr	96.5
Exhaust temperature at rated kW, dry exhaust, °C (°F)	550 (1022)
Maximum allowable back pressure, kPa (in.Hg)	6 (1.77)
Exhaust outlet size at engine hookup, mm (in.)	40 (1.57)

### Engine Electrical

#### Engine Electrical System

Battery charging alternator	12 Volt
Ground (negative/positive)	Negative
Volts, VDC	12
Amps, Ah	20
Battery type - sealed maintenance free (PLT)	
- Qty.	1
Battery voltage, VDC	12

### Fuel

#### Fuel System

Fuel supply line, min. ID, mm (in.)	4 (0.15)
Fuel return line, mm. ID, mm (in.)	6 (0.23)
Fuel prime pump	MICO/Bosch
Fuelfilter:quantity,type	1,Dualelement
Recommended fuel	#2 Diesel
Fuel tank capacity, L	93

### Lubrication

#### Lubricating System

Type	Full pressure
Oil pan capacity, L (qt.)	5 (5.3)
Oilpancapacitywithfilter,L(qt.)	6(6.3)
Oilfilter:quantity,type	1,Spinon

# Application Data

## Cooling

### radiator System

Ambient temperature, °C (°F)	50 (122)
Engine jacket water capacity, L (gal.)	4.5 (1.19)
Radiator system capacity, including engine, L (gal.)	10.9 (2.9)
Heat rejected to cooling water at rated kW, dry exhaust, kW (Btu/min.)	18.07 (1028)
Water pump type	Impeller
Fan diameter, including blades, mm (in.)	406.5 (16)
Fan, kWm (HP)	0.55 (0.75)

## Operation Requirements

### Air Requirements

Radiator-cooled cooling air, m <sup>3</sup> /min (scfm)	65 (2292)
Combustion air, kg/hr	92
Heat rejected to ambient air : Generator, kW (Btu/min.)	2.85 (162)

### Fuel Consumption

Diesel, Lph (gph) at % load@0.8 Pf	Prime rating
100%	4.0 (1.06)
75%	3.0 (0.8)
50%	2.0 (0.53)

### Exhaust Emissions

Per ISO 8178-5 mode cycle	CPCB norms
---------------------------	------------

### Noise Level

Measured at 1m per CPCB norms, db(A)	71.4
--------------------------------------	------

## Controller

### Standard Features and Accessories

#### Standard Features

- Master switch: Run/Off-Reset/Auto
- Remote two-wire start/stop capability
- Event log
- Superior electronics
- Factory-built and production-tested
- One-source responsibility for the generating system and accessories
- Automatic start with programmed cranking cycle
- Field software upgrade possibility

#### Environmental Specifications

- Operating temperature: -20°C to 70°C (-4°F to 158°F)
- Storage temperature: -40°C to 85°C (-40°F to 185°F)
- Humidity: 0-95% condensing

#### Power Requirements

- 12 or 24 VDC with fuse protection
- 250 mA @ 12 VDC
- 125 mA @ 24 VDC

#### Accessories

- Battery charger 12 V
- Mains sensing relay
- Earth leaking protection

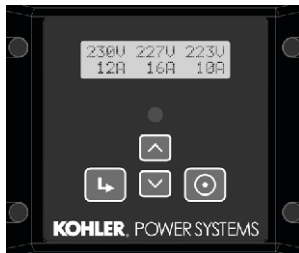

## Advance Digital Control (ADC 2200)

### Compact Controller

LCD display:

- Runtime hours
- Current
- Voltage
- Frequency
- Engine Temperature
- Engine oil pressure
- Battery V
- Kilowatt

LCD display faults:

- High engine temperature
- Low oil pressure
- Overspeed
- Over & under voltage
- Over & under frequency
- E-stop
- Auxiliary fault
- Low Fuel level
- Over Load

Display warning:

- Low battery voltage
- High battery voltage

KOHLER CO., Kohler,  
 Wisconsin 53044 USA  
 Phone 920-565-3381,  
 Fax 920-49-1646  
 KohlerPower.com

Kohler Power Systems  
 AsiaPacificHeadquarters  
 7 Jurong Pier Road  
 Singapore 619159  
 Phone (65) 6264-6422, Fax (65) 6264-6455  
 Kohler.com.sg

Kohler India Corporation Pvt Ltd  
 #138/6, 6th 'A' Cross  
 RajMahalVilasExtensionSadashivnagar  
 Bangalore 560 080, India  
 Phone +91 80 2361 6208 / 6831 / 0231  
 Fax +01 80 2361 5972  
 E-mail: info@kohlerindia.com

**Dimensions and Weights**

Overall Size, L x W x H, mm (in.)	1997 x 950 x 1485 (78.6 x 37.4 x 58.5)
Wet, max., kg (lb.)	950 (2090)
Dry, max., kg (lb.)	800 (1760)

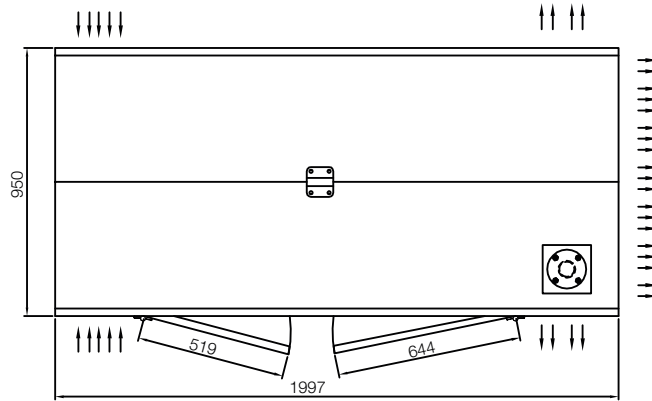

**TOP VIEW**

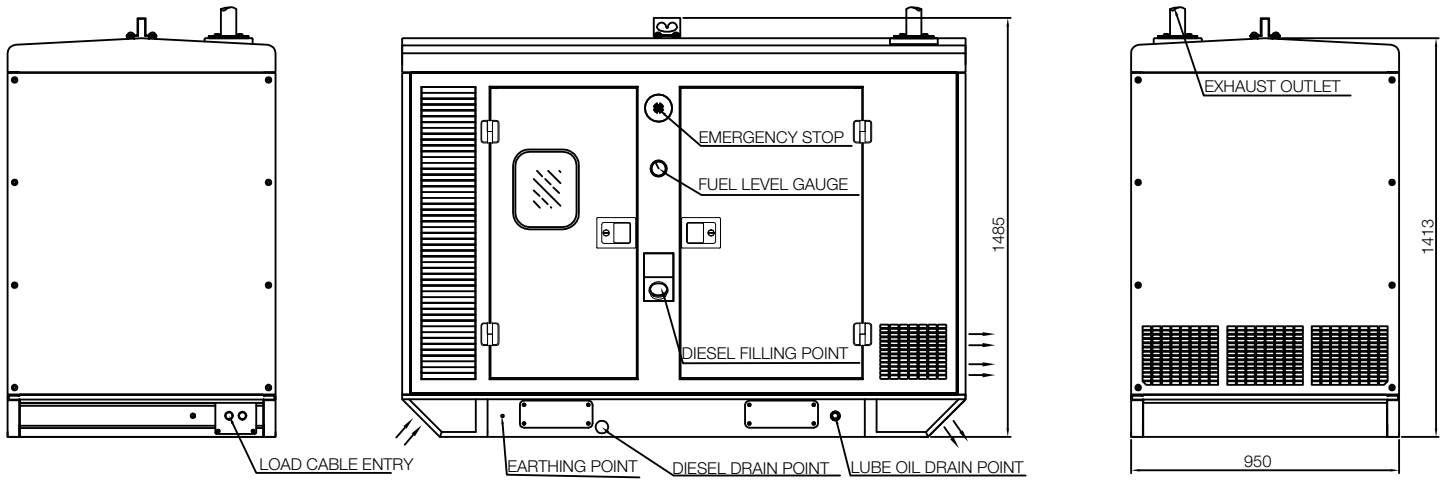

NOTE: This drawing is provided for reference only and should not be used for planning installation. Contact your local distributor for more detailed information.

**DISTRIBUTED BY:**

© 2012 by Kohler Co. All rights reserved.