

IVECO

70C15H Twin Rear Wheels

B.O HPI

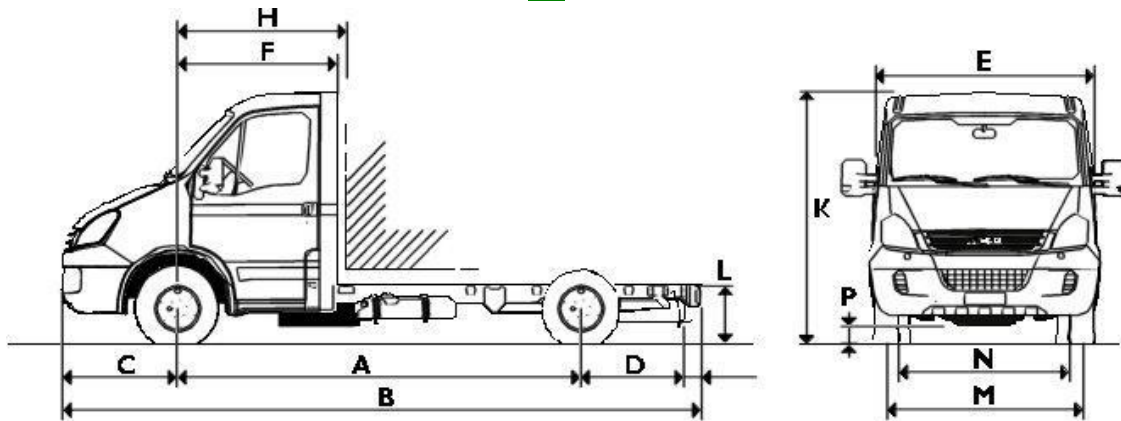

DIMENSIONS (mm)

A Wheel base	3450	3750	4350	4750
B Maximum Length	5905	6515	7340	8200
C Front Overhang	998			
E Max Cab width	2060			
F Front Axle / Rear Cab	1355			
H Front axle/Front Body	1410			
K Overall Height (Unladen)	2335	2330	2325	2320
M Front Track	1725			
N Rear Track	1661			
L Unladen Frame Height at Rear of Frame	788	788	788	787
P Front Ground Clearance	171			
D Rear Overhang	1355	1665	1890	2350
Turning circle: kerb/kerb	12240	13180	14620	16240
Turning circle: wall/wall	13340	14280	16120	17360
Fix Body Dimensions (OPTIONAL)				
Body Length (Internal)	3500	4100	5240	6100
Maximum Body Width (Ext)	2300			
Side height	400	400	500	500

Weights (Kg) *

GVW	7000			
GTW	10500			
Front Axle Capacity	2500			
Rear Axle Capacity	5350			
Kerb Weight Front Axle	1450	1460	1495	1495
Kerb Weight Rear Axle	795	800	800	830
Kerb Weight Total	2245	2260	2295	2325
Max Body and Payload Capacity	4755	4740	4705	4675

* Weights for chassis cab are with full fuel, oils, water and include driver.

The information in this literature is intended to be of general nature only. Iveco reserves the right to modify or change specifications at any time. For more detailed information refer to your dealer.

70C15H

ENGINE

Type F1C E0481- 4 stroke diesel cycle-Watercooled-16 valves (4 per cylinder)
 - DOHC - High Pressure Common Rail direct injection + EDC
 - Turbocharger and intercooler + Wastegate - Cast-iron engine
 block with aluminium cylinder head - Suspended Oil Sump - Dual mass flywheel.
 Integrated Vacuum and Steering Pumps . Glow plugs . Blow - by system .

Basic data

Number of Cylinders	4 In Line
Bore x Stroke	95,8 mm x 104 mm
Total Displacement	2998 cm ³
Maximum Output	107 kW (146 hp) at 3000 ÷ 3500 rpm
Maximum Torque	350 Nm at 1400:2600 rpm
Green Zone	1500 - 2750 rpm

Emission according **Euro 3**

FRAME

C Section steel longitudinal side members with tapered ends and tubular cross members.

Wheel base	3450	3750	4350	4750
Number of Cross Members	6	6	7	8
Side Member Height	184	184	184	184
Side Member Width	69	69	69	69
Side Member Thickness	5	5	5	5

TRANSMISSION

Six speeds Overdrive ,synchroneshed manual transmission.
 Push/Pull cable control. Gear Lever on Dashboard .

Performance rating (calculated value with standard tyres and axle ratio):

Gear	Gear Ratio	Maximum Geared Speed (Km/h)	Gradeability at GVW (%)
1°:	5,37	--	> 30
6°:	0,79	120	--

Power Take-Off

Facility for side mounted PTO. Maximum torque output : 180 Nm.

CLUTCH

Single dry plate hydraulic.
 External Diameter: 279,5 mm (11").
 Total Contact Surface: 772 cm²

FRONT AXLE

Independent wheels.

REAR AXLE

Axle Ratio (Standard) : 4,556

SUSPENSION

Front

Independent with Torsion Bar .
 Anti-roll bar is Standard.

Rear

Semielliptical leaf spring and additional bumpers.
 Anti-roll bar is Standard.
Shock Absorbers
 Front and rear heavy duty hydraulic telescopic shock absorbers.

ELECTRICAL SYSTEM

New CAN Bus digital communication line electrical system. According to EU rules.
 Voltage: 12 volt (dual positive poles for additional service)
 Battery maintenance free:12 Volt-110 Ah
 Alternator : 110 Ah(140 Ah,opt.)
 Starter: 2.3 kW
 Electric outlet for body and auxiliary equipments: in-cab in the fuses box and inside the engine bonnet

3.0 HPI - 146HP

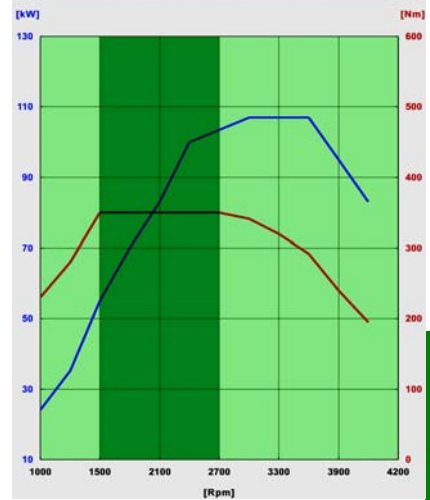

BRAKING SYSTEM

Ventilated Disc brakes front and rear.

Brake Dimensions : Front / Rear

Disc Diameter (mm) : 301 / 306

Brake Calipers(n°xmm) : 2x60 / 2x48

Service and Emergency

Dual circuit with vacuum servo.
 Floating disc caliper with auto wear adjustment . Brake level pad front / rear wear indicators.
 Asbestos free pads
 Emergency brake built into the service brake system.

Parking Brake

Manual brake operating on rear wheels.

ABS 8 Standard

STEERING

Power steering. Diameter of steering wheel is 420 mm, with steering lock. Three piece steering column with connecting universal joints.

WHEELS / TYRES (Standard)

Tyres: (6 + 1 spares) 225/75 R 16

Wheels: 6J - 16H2

OTHER EQUIPMENT

Spare wheel under the rear overhang.
 100 litre sole shaped fuel tank, with fuel filler on cab pillar. with key lock.
 Front and Rear integrated Fog Lights
 New wide angle rearview mirrors with integrated indicators lights.
 New instrument cluster LCD display
 Front recovery eye.
 Exhaust pipe with manifold longitudinally positioned on the right side with stub-pipe outlet placed within the side members.

IVECO

Rel.1 - 06/2010